

Melbourne-Tillman Water Control District



Board Agenda

Melbourne-Tillman Water Control District

MEETING OF THE BOARD OF DIRECTORS

TUESDAY, FEBRUARY 27, 2024

9:00 AM



Call to Order

Phil Weinberg, President

Pledge of Allegiance

Phil Weinberg, President

Roll Call

Lisa Blackett

Board Members:

Joseph Hale (Palm Bay September 30, 2025)
Brant Hoffman (Brevard County September 30, 2025)
Keith Jerdon, (West Melbourne September 30, 2024)
Don Jordan, (Palm Bay September 30, 2026)
Drew Powshok (Brevard County September 30, 2025)
Philip Weinberg, (Palm Bay September 30, 2024)
Jay Woltering (Brevard County September 30, 2025)

Staff & Support:

Rick Nipper, District Manager
Lisa Blackett, Assistant Manager/Admin, Secretary/Treasurer
Jim Beadle, Attorney

Recognition of Guests and Support Staff

Bo Rainbolt, Assistant Manager/ Operations
Mike McCabe, District Engineer

Announcements

Public Comments

Presentations

- The City of Palm Bay permit fee waiver request (Attachment 1)

Regular Business

- Approval of the December 5, 2023 minutes of the MTWCD Board of Director's Meeting (Attachment 2)
- Approval of the Operating Statement through January 31, 2024 (Attachment 3)

Melbourne-Tillman Water Control District

MEETING OF THE BOARD OF DIRECTORS

TUESDAY, FEBRUARY 27, 2024

9:00 AM

New Business

- District Manager's Annual Review
- Board Consideration of Florida Retirement System employee contribution

Old Business

- AT&T Installation on C-51 West of Emerson without a permit, continued from June 27, 2023

Budget

Staff Reports

- District Manager's Report, Rick Nipper
 - District Operations
 - District's User Fee Cap Legislation
- Engineer's Report, Mike McCabe
 - Update on Permit applications and issued permits
 - Update on installation of Gas line along 7-11
- Assistant Manager, Operations Report, George Rainbolt
 - Field Operations
- Attorney's Report, Jim Beadle
- Secretary/Treasurer's Report, Lisa Blackett
 - District's Annual Audit
 - FEMA Claim Update
 - FRS Contribution Rates

Closing

- Meeting Schedule – The next Board Meeting is scheduled for Tuesday, April 23, 2024 at 9:00 am in the City of West Melbourne Council Chambers.
- Board Member Reports
 - Joe Hale
 - Brant Hoffman
 - Keith Jerdon
 - Don Jordan
 - Drew Powshok
 - Phillip Weinberg
 - Jay Woltering
- Adjourn

If a Board Member has a request for any agenda item you may raise it at any time or you may let staff know and it will be formally included in the agenda package distributed to the Board prior to each meeting. As usual, staff is available in person, by telephone, or by e-mail to discuss the agenda prior to each and every Board Meeting.

Attachment

1



MELBOURNE-TILLMAN WATER CONTROL DISTRICT

5990 Minton Road, Palm Bay, Florida 32907

321-723-7233

Fax 321-725-5933

MEMORANDUM

TO: Rick Nipper, District Manager

FROM: Michael E. McCabe, District Engineer *//////*

SUBJECT: Request for parallel use of Canals C-1 and C-37

DATE: February 21, 2024

The City of Palm Bay previously applied and issued a permit for installation of conduits for fiber optic cable from Palm Bay City Hall along east side of Canal C-37 crossing Canals C-51 and C-1, then easterly along north right-of-way to Florida Power & Light's transmission lines upstream of MS-1. At this location the conduit continues north to Palm Bay Community Center on Port Malabar Boulevard, then eventually along southside of Port Malabar Boulevard to the North Regional Treatment Plant (NTRP) on Clearmont Street (See attachments 1 through 3).

During the process of purging open permit files, discovery of permit for this job was identified as expired beyond time of issuance (5 years). An email sent to the City of Palm Bay on September 28, 2023 identified the expiration of permit and requirement of new permit meeting current policy standards (Attachment 4).

Research of files identified an as-built drawing showing a portion of the work completed for conduit installation under I-95 bridge and under Babcock Street (Attachment 5).

An email response from expiration notification was received from Jim Poirier on January 16, 2024 requesting placement on the February 27th Board Agenda to discuss continuation of the project as previously permitted with waiver of fees as currently identified in the Permitting Policy. Current policies enacted that do not meet the original plan include fees for new installation including municipalities, depths for crossings of canals (14' for major, 6' for minor), and distance from right-of-way (3' maximum). See attachments 6 & 7 for details from original plan. See attachment 8 for calculation of fees.

Parallel use requests, according to policy, requires identification of hardship of other locations for installation prior to requesting use of MTWCD canals. I have inquired as to whether the 20' Public Utilities and Drainage Easements identified on the plats of parcels adjacent to the canal rights-of-way were evaluated and verbal response was the accessibility of properties for installation, maintenance, and security.

If you have any questions, I'm available to provide guidance.

w/attachments

ENDORSEMENT No. 1 TO PERMIT MT-27-10	Melbourne-Tillman Water Control District
ISSUED TO:	5990 Minton Road, Palm Bay, Florida 32907 321.723.7233 Fax 321.725.5933 mtwcd@cfl.rr.com

Name: City of Palm Bay
 ATTN: Lee R Feldman, City Manager
 Address: 120 Palm Bay Road
 City, State, Zip: Palm Bay, FL 32907

Telephone: 321-952-3400 Fax: 321-952-3412 E-Mail: feldm@pbfl.org

ISSUE DATE: **01/03/2011**

ENDORSEMENT:

As per attached correspondence from Hector I Franco, PE, City of Palm Bay, this permit endorsement will authorize replacement of the dual 1-1/4" schedule 40 HDPE pipes with dual 2" schedule 40 HDPE pipes.
--

IMPORTANT: This Endorsement is hereby made part of Permit MT-27-10. Please make it part of your records.

AUTHORIZED BY: Melbourne-Tillman Water Control District

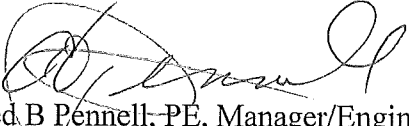
By: 
 Alfred B Pennell, PE, Manager/Engineer
 For the Board of Directors

COPIED TO AGENT/ENGINEER:
 CITY OF PALM BAY PUBLIC WORKS DEPT, 1050 MALABAR ROAD, PALM BAY, FL 32907 ... ATTN: HECTOR I FRANCO, PE

PERMIT MT-27-10 Incorporating PA 100617_01	MELBOURNE-TILLMAN WATER CONTROL DISTRICT
ISSUED TO:	5990 Minton Road, Palm Bay, Florida 32907 321.723.7233 Fax 321.725.5933 mtwcd@cfl.rr.com

Name: City of Palm Bay
 ATTN: Lee R. Feldman, City Manager
 Address: 120 Malabar Rd.
 City, State, Zip: Palm Bay, Fl. 32907

Telephone: 321-952-3400 Fax: 321-952-3412 E-Mail: feldm@pbfl.org

ISSUE DATE: **6/21/2010**

PERMIT NOT VALID FOR CONSTRUCTION 5 YEARS AFTER ISSUED DATE

AUTHORIZING:

Installation of a dual conduit for fiber optic cable in the MTWCD canal c-01 right-of-way as specified herein and as shown on plans prepared by the City of Palm Bay Public Works Department titled "Fiber Optic Layout-Phase 4 Construction Plans", dated, signed, and sealed 07 April 2010 T.J. Tiedeman, Jr., PE.

Minimum cover throughout is 36" unless otherwise noted. Surface features shall be flush with the ground and be traffic bearing to include all District maintenance equipment.

Authorization to install dual 1¼" Schedule 40 HDPE conduit for fiber optic cable, the centerline of which to lie within the northern-most 5-feet of the MTWCD canal c-01 right-of-way, from a point beginning at the sub-aqueous crossing of canal c-01 noted below (approximately mid Lot 9, Block 2439 PM Unit 45), east to Emerson Drive, a distance of approximately 7,950 feet; as shown on sheets 3, 4, and 7 referenced plans.

Authorization to install dual 1¼" Schedule 40 HDPE conduit for fiber optic cable, the centerline of which to lie within the northern-most 10-feet of the MTWCD canal c-01 right-of-way, from Emerson Drive east to the eastern boundary of PM Unit 5, a distance of approximately 12,800 feet; as shown on sheets 4-7 of referenced plans.

Deviations authorized beyond the 5 and 10-foot authorized offset include:

1. Transition up to 20 feet to cross Emerson Drive, extending approximately 300 feet both east and west (Sheet 4).

Main canal crossings include:

1. A sub-aqueous crossing of MTWCD canal c-01 having a minimum cover from the channel bottom of 36"; approximately 600' east of Minton Road (Sheets 3 and 7).

Lateral water main connections include:

1. Fiber Optic Cable Phase 4A connecting northward along the eastern boundary of Block 118 PMCC Unit 1, approximately 600' east of Minton Road (Sheets 3 and 7).
2. Continuation of Fiber Optic Cable Phase 4 running northward along the eastern boundary of PM Unit 5, approximately 225' west of MS-1 (Sheet 5).

SUBJECT TO STANDARD AND SPECIAL CONDITIONS AS NOTED

NOTES:

1. This Permit includes:
 - a. The Permit Application attached hereto, which, by reference, including all plans, reports, and specifications, is made a part hereof, and
 - a. The Notice of Completion, which must be completed and returned within 30 days of project completion to schedule a final inspection.
2. This Permit does not convey to OWNER any property rights or any rights or privileges other than those specified herein, nor relieve the permittee from complying with any law, regulation or requirement affecting the rights of other bodies or agencies.
3. All structures and works installed by OWNER hereunder shall remain the property of the OWNER and shall be operated and maintained by the OWNER in perpetuity.
4. Responsibility for ownership, operation and maintenance may be transferred to another entity acceptable to the district upon written notification, signed by the OWNER and the new ENTITY that said transfer is requested and that all conditions of the permit are accepted.
5. The OWNER agrees to hold and save the MTWCD and its successors harmless from any and all damages, claims, or liabilities that may arise from permit issuance.
6. The OWNER agrees to alter or remove the authorized use or construction, as permitted if required in the interest of future drainage requirements of the MTWCD.

STANDARD CONDITIONS:

1. Contractor:
 - a. As stated in application.
 - b. OWNER must name contractor and so notify MTWCD for permit to be valid.
2. Start of Work:
 - a. Within 90 days of Permit Date as stated in application or OWNER / Contractor must notify MTWCD prior to start date.
 - b. OWNER / Contractor must notify MTWCD prior to start date.
3. Construction Dewatering:
 - a. Authorized as specified herein.
 - b. Not authorized.
 - c. Requires separate application by OWNER or Contractor. Fee waived if copy of SJRWMD permit for construction dewatering, including applicable Form RDS-50, is submitted.
4. Any erosion to or shoaling in the canal or flooding due to the permitted works, or failure thereof, shall be the responsibility of the OWNER to remove, repair or correct at no cost to the MTWCD.
5. All disturbed areas within MTWCD rights-of-way to be sodded.
6. Subject to final inspection by MTWCD.
7. OWNER to provide MTWCD with as-built plans upon completion of project.
8. This permit does not preclude the OWNER from obtaining any and all other pertinent permits from other agencies.

SPECIAL CONDITIONS:

AUTHORIZED BY: Melbourne-Tillman Water Control District

By:

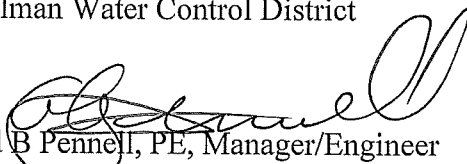

Alfred B Pennell, PE, Manager/Engineer
For the Board of Directors

COPIED TO AGENT/ENGINEER:

CITY OF PALM BAY PUBLIC WORKS DEPT., ATTN: T.J. TIEDMAN PE, 1050 MALABAR RD. PALM BAY, FL. 32907

FIBER OPTIC LAYOUT - PHASE 4 CONSTRUCTION PLANS

MARCH 2008

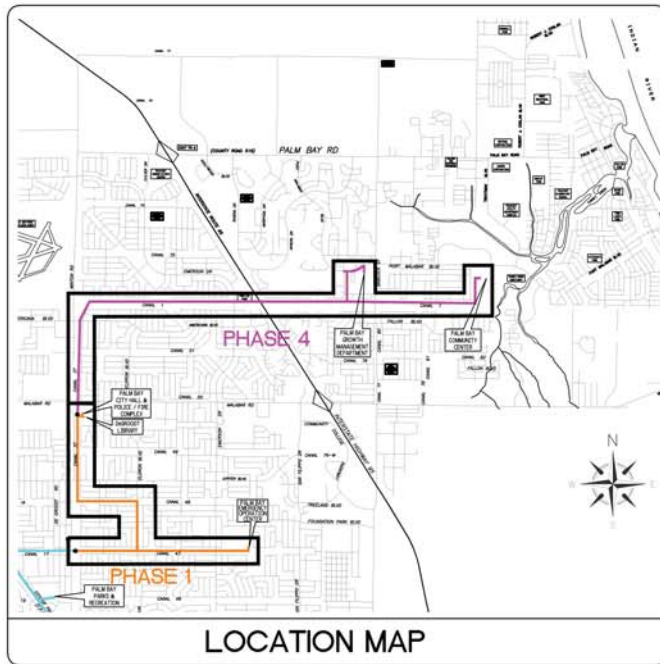

UTILITIES ENCOUNTERED			
FLORIDA POWER AND LIGHT	(POWER)	(321)	726-4826
BRIGHT HOUSE NETWORKS	(CABLE)	(321)	757-6503
A T & T	(TELEPHONE)	(321)	953-4846
FLORIDA CITY GAS	(GAS)	(800)	432-4770
PALM BAY UTILITY DEPARTMENT	(WATER & SEWER)	(321)	952-3410
PALM BAY I2D	(F.O.C.)	(321)	952-3475
FDOT-INTELLIGENT TRANSPORTATION SYSTEMS (F.O.C.)	(407)		736-1906

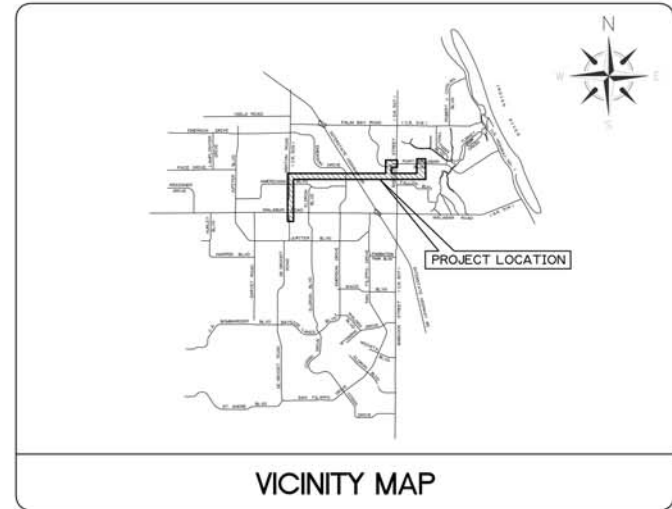

INDEX OF SHEETS	
1	COVER SHEET
2	GENERAL NOTES
3	PLAN VIEW
4	PLAN VIEW
5	PLAN VIEW
6	PLAN VIEW - BABCOCK STREET & INTERSTATE 95 CROSSING
7	MISCELLANEOUS DETAILS
8	EROSION CONTROL AND M.O.T. DETAILS
9	CROSS SECTIONS - BABCOCK STREET & INTERSTATE 95

City of Palm Bay Fiber Optics Phase 4 Location Map

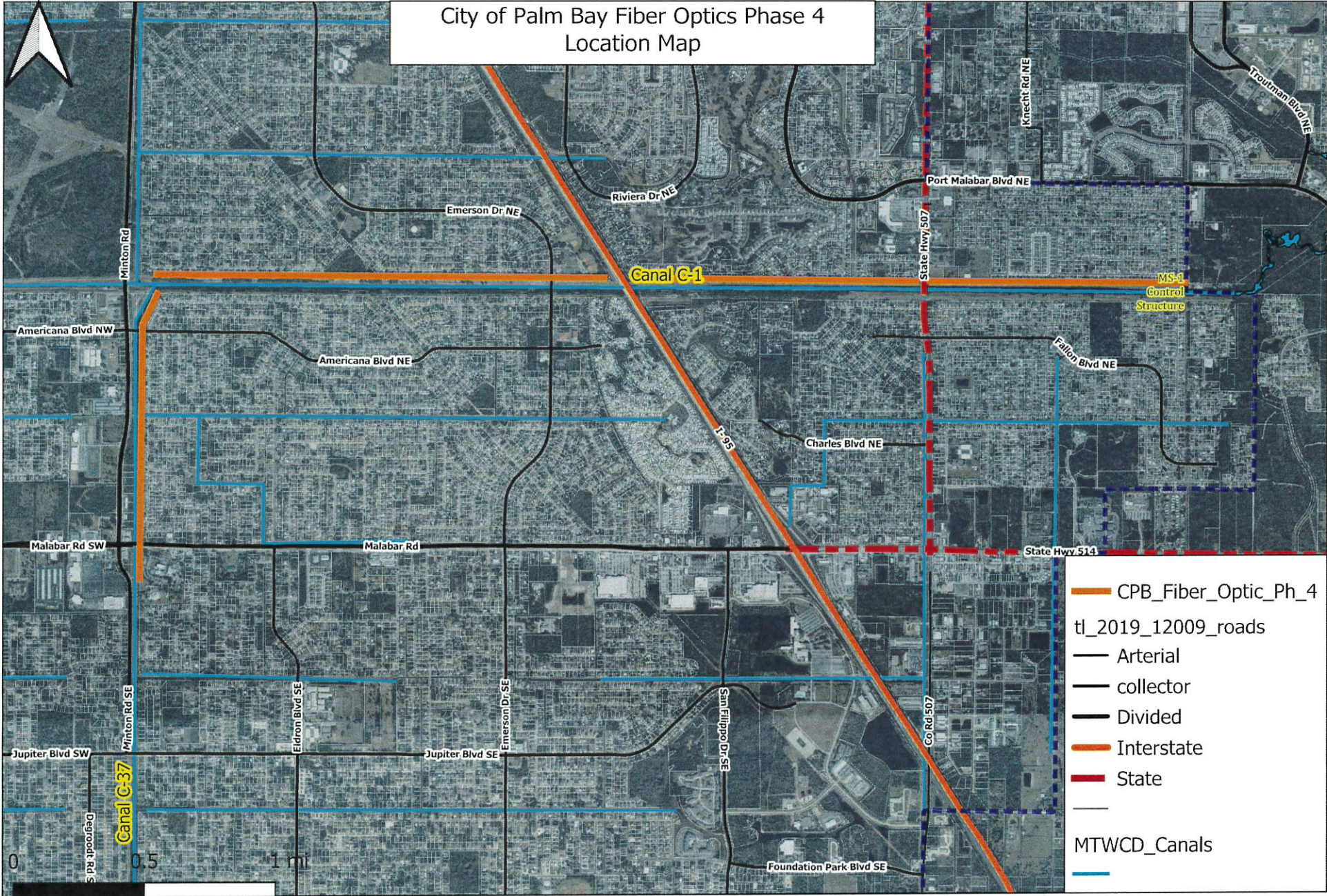

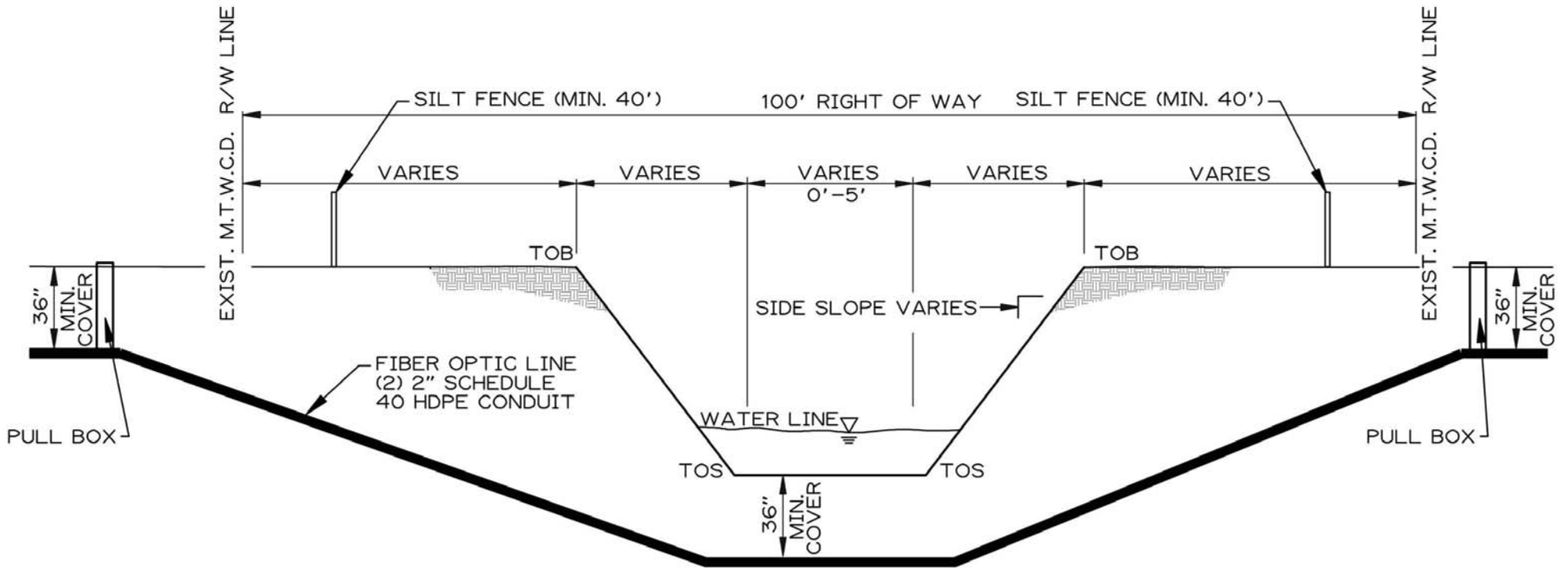

D-1

TYPICAL CANAL CROSSING DETAIL

N.T.S.

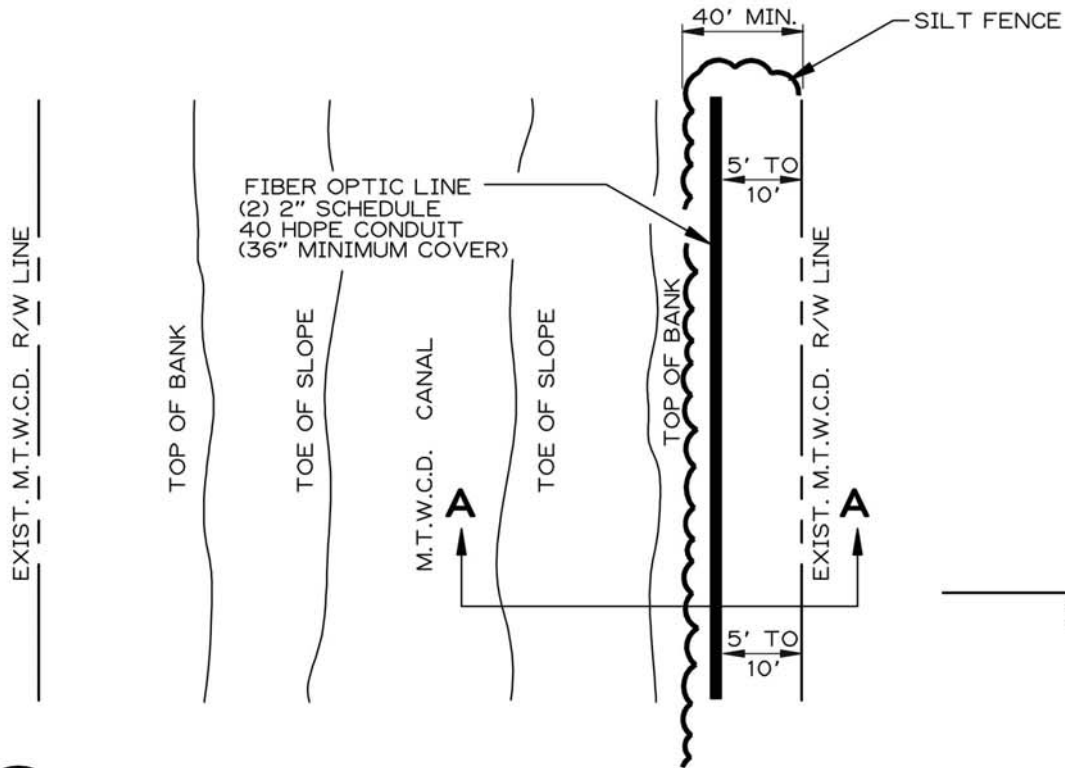

D-5 **TYPICAL CANAL PLAN VIEW DETAIL**
N.T.S.

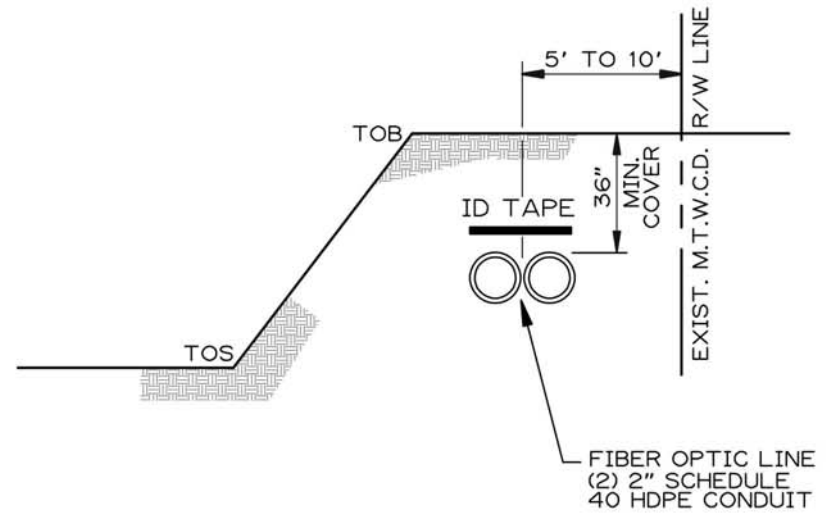

SECTION A-A
N.T.S.

City of Palm Bay Fiber Optic Phase 4 City Hall to Community Center

Segment_ID	Parallel Length (LF)	Description (Canal #, From-To)	Cost (\$24/LF)	\$750	Total Cost
1	595.3	C-37 City Hall to Malabar Road	14287.2	750	\$ 15,037.20
2	2514.3	C-37 Malabar Road to S. ROW C-51	60343.2	750	\$ 61,093.20
3	2450	C-37 N. ROW C-51 to S. ROW C-1	58800	750	\$ 59,550.00
4	9024.3	C-1 X-ing C-37 to I-95	216583.2	750	\$ 217,333.20
6	5676.2	C-1 I-95 to Babcock	136228.8	750	\$ 136,978.80
7	5160.5	C-1 Babcock to FPL transmission line	123852	750	\$ 124,602.00

\$ 614,594.40 Total

Segment_ID	Perpendicular Length (LF)	Description (Canal #)	Cost (\$18/LF)	\$750	Total Cost
8	128	C-51	2304	750	\$ 3,054.00
9	396	C-1	7128	750	\$ 7,878.00

\$ 10,932.00 Total

\$ 625,526.40 Grand Total

Attachment

2

MELBOURNE-TILLMAN WATER CONTROL DISTRICT

MINUTES

December 5, 2023

CALL TO ORDER

The regular scheduled meeting of the Melbourne-Tillman Water Control District (MTWCD) Board of Directors was called to order by Philip Weinberg, President on Tuesday, December 5, 2023 at 9:00 AM in the City of West Melbourne Council Chambers, Veterans Memorial Complex, 2285 Minton Road, West Melbourne, Florida.

PLEDGE OF ALLEGIANCE

The Pledge of Allegiance to the Flag was recited by all present.

ROLL CALL

The following Board Members were present:

Philip Weinberg, Board President
Joe Hale, Vice President
Drew Powshok
Don Jordan
Brant Hoffman
Jay Woltering

Absent: Keith Jerdon

Also present:

Rick Nipper, District Manager
Lisa Blackett, Assistant Manager/Administration/Secretary/Treasurer
Jim Beadle, District Attorney

RECOGNITION OF GUESTS/VISITORS/STAFF

Bo Rainbolt, Assistant Manager/Operations
Mike McCabe, District Engineer

ANNOUNCEMENTS

The District Manager announced that the District's annual Christmas Party would be held on December 21, 2023 at Fred Poppe Park.

The District Manager announced the District's office would be open during the week between Christmas and New Years Day.

PUBLIC COMMENTS

None.

PRESENTATIONS

None.

REGULAR BUSINESS

The President presented the minutes from the October 24, 2023 Board meeting for approval. Drew Powshok **motioned to approve the minutes of the October 24, 2023 Board meeting**. Don Jordan **seconded the motion**. The Board **voted 6-0 to approve the minutes**.

The President presented the Operating Statement through November 30, 2023 for Board approval. Drew Powshok **motioned to approve the Operating Statement through November 30, 2023**. Jay Woltering **seconded the motion**. The Board **voted 6-0 at approve the motion**.

NEW BUSINESS

None.

OLD BUSINESS

The District Manager requested to table until the next Board meeting the AT&T installation on C-51 due to the difficulty in contacting the appropriate responsible party. The Manager added that the recent rains created a washout which exposed a potential second unpermitted crossing at Walden would be included.

BUDGET

None.

MANAGER'S REPORT

The Manager stated that the recent heavy rains of 9 ½ - 10 inches in the Palm Bay area caused flooding in the southern parts of Palm Bay. He added the coffer dam in place at Walden collapsed during the flooding but the repairs being made were moving forward.

The Manager advised the Board that he was notified by the Westbrooke Homeowner's Association that a homeowner in the subdivision had built a dock that included steps and structures for kayaks in the canal behind his home. He said the HOA deemed the structure a violation and stopped the closing on the sale of the home until it was removed. The Manager reported that the Assistant Manager/Operations had been in contact with the homeowner to remove the structures from the canal.

The Manager reported the scope of work along C-69 had been evaluated and staff has concluded the scope is larger than District staff can complete. He added the scope had been reduced to removing trees from the water's edge up to the bank which will avert demolishing the landscaping at the entrance of the Tuscany neighborhood and open up the right of way.

The District Manager reported staff removed the pumps and would conduct monthly inspections by the District mechanics to ensure the pumps are in top working order. He also added that the District would not use rental pumps during the upcoming hurricane season.

Jay Woltering asked the Manager how severe the washouts from the recent rains were and what plans had been made to repair. The Manager replied the repair of the washouts is costly and the increased number of washouts had depleted the District's stock pile of fill dirt. The Board President said these repairs show the need for the user fee cap increase legislation be passed.

ENGINEER'S REPORT

The District Engineer advised the District had received the final reimbursement of \$218,000 from the SOIRL program total of \$1,001,000.

The Engineer announced he and the Manager would attend the resiliency meeting hosted by the City of Palm Bay to represent the District's interests in obtaining funding to evaluate the MS-1 bulkhead walls.

The Engineer reported that permit applications continued to be robust especially along the Parkway. He added that despite the fact the utility permit applications have slowed, utility permits in the compound area of Palm Bay have increased.

The Engineer said the District has worked with the City of Palm Bay to make repairs to the road failures and collapses. He added some of the failures have been replaced temporarily but the District is committed to be of whatever assistance possible to expedite the repairs.

Joe Hale asked if District staff would be onsite when the planned gas line is installed under the canal at Palm Bay City Hall. The Engineer replied he had spoke with a representative from the contractor, who advised possible changes to the plan to install which would put the gas line in the Malabar Road right of way eliminating the need for an easement. The Engineer stated he would update at the next meeting.

ASSISTANT MANAGER/OPERATIONS REPORT

The Assistant Manager/Operations reported that the mowers were in the south end of the District and the aquatics operations have been halted by the heavy rains but that once the normal water levels return, staff would return to normal operations. He added the two new facilities group employees were working out well and the heavy equipment group was repairing washouts caused by the heavy rains.

The Assistant Manager/Operations recognized two District employees, Ken Neff and Shawn Hughes for assisting a resident find the cause of a bad smell coming from the canal behind her home. The resident was pleased to have found the source of the smell and appreciated the staff from Melbourne Tillman would take the time to respond when other entities ignored her request.

Jay Woltering asked the Assistant Manager/Operations how the harvester was doing. He responded that due the high flows the harvester had not been used but the machine is repaired and would to return to full operation.

Joe Hale expressed concern regarding the failed crossing on C-20 being an attractive nuisance liability for the District. The District Engineer stated the area was barricaded and stated he believed the City of Palm Bay had initiated code enforcement action. The District Attorney advised if the structure was permitted to an owner then that would be the responsible party.

ATTORNEY'S REPORT

None.

SECRETARY/TREASURER'S REPORT

The Secretary/Treasurer reported that the auditors had completed the planning and onsite portions of the District's annual financial audit with no issues found.

The Secretary/Treasurer updated that the RAI request from the FEMA state review consultants had been completed. She added the amount is \$265,490 for equipment costs and did not expect that amount to be reduced once the review is completed. The Secretary/Treasurer said once the equipment costs and administrative costs of approximately \$50,000 were completed the final closeout review from FEMA representing the final step of the process would be initiated.

CLOSING

The Board President stated that the next Board meeting would be Tuesday, February 27, 2024 at 9:00 AM in the City of West Melbourne Council Chambers, Veterans Memorial Complex, 2285 Minton Road, West Melbourne, Florida.

DIRECTOR'S REPORTS

Joe Hale – Mr. Hale stated during the recent rains he felt staff did a better job of making the City of Palm Bay staff more aware of how the process works which reduced complaints he received from the city's staff.

Brant Hoffman – *Just to add on what Joe said, from what Mike sent in to us with the rainfall totals and stuff was a big help.*

Jay Woltering – None

Don Jordan – None

Drew Powshok – None

Philip Weinberg – *The Board President thanked the Board Members for another year of service.*

ADJOURN

Philip Weinberg, Board President, adjourned the meeting at 10:00 am.

Respectfully,

Lisa Blackett
Secretary
Board of Directors

Attachment

3



MELBOURNE-TILLMAN WATER CONTROL DISTRICT
 Operating Statement Through January 31, 2024

	Actual \$	FY 2024	Approved Budget	FY 2023	Over/Under	Percentage
	To Date	Approved Budget	Adjustment	Modified Budget	Budget	Budget
Revenue						
User Fees	\$ 1,886,842	\$ 2,416,125		\$ 2,416,125	\$ (529,283)	78%
Permits	\$ 15,749	\$ 40,000		\$ 40,000	\$ (24,251)	39%
Miscellaneous Income	\$ 82,605	\$ 50,000		\$ 50,000	\$ 32,605	165%
Other Income	\$ -	\$ -	\$ -	\$ -	\$ -	
State Grant - FEMA		\$ -		\$ -	\$ -	100%
Federal Grant - FEMA		\$ -		\$ -	\$ -	100%
Intergovernmental Revenue				\$ -	\$ -	100%
Revenue	\$ 1,985,196	\$ 2,506,125	\$ -	\$ 2,506,125	\$ (520,929)	79%
Balance Forward		\$ 2,199,679		\$ 2,199,679	\$ (2,199,679)	0%
TOTAL INCOME	\$ 1,985,196	\$ 4,705,804	\$ -	\$ 4,705,804	\$ 2,720,608	42%
Expenses						
Salary & Benefits						
Uniform Reimbursement						
Salaries	\$ 354,647	\$ 1,147,842		\$ 1,147,842	\$ 793,195	31%
Health Insurance	\$ 109,289	\$ 282,960		\$ 282,960	\$ 173,671	39%
Retirement	\$ 48,126	\$ 182,736		\$ 182,736	\$ 134,610	26%
FICA/Medicare	\$ 26,247	\$ 87,465		\$ 87,465	\$ 61,218	30%
Workers' Comp	\$ 5,896	\$ 35,755		\$ 35,755	\$ 29,859	16%
SALARY & BENEFITS	\$ 544,204	\$ 1,736,758	\$ -	\$ 1,736,758	\$ 1,192,554	31%
Operations						
Professional Services	\$ 19,750	\$ 53,100		\$ 53,100	\$ 33,350	37% <i>Testing, Miscellaneous Professional Services</i>
Contract Services	\$ 2,057	\$ 7,300		\$ 7,300	\$ 5,243	28% <i>Uniforms, Garbage Service</i>
Travel	\$ 20	\$ 1,200		\$ 1,200	\$ 1,180	2% <i>Travel</i>
Communications	\$ 2,911	\$ 10,500		\$ 10,500	\$ 7,589	28% <i>Postage, Telephone Service</i>
Utilities	\$ 2,155	\$ 8,375		\$ 8,375	\$ 6,220	26% <i>Utility, Solid Waste Assessment</i>
Rentals	\$ 5,684	\$ 13,500		\$ 13,500	\$ 7,816	42% <i>Rentals</i>
Liability Insurance	\$ 130,407	\$ 144,098	\$ (10,928) 1	\$ 133,170	\$ 2,763	98% <i>Insurance</i>
Repair & Maintenance	\$ 27,768	\$ 188,507	\$ -	\$ 188,507	\$ 160,739	15% <i>Repair & Maintenance Service, Repair & Maintenance Supplies,</i>
Current Charges	\$ 43,552	\$ 50,323		\$ 50,323	\$ 6,771	87% <i>Tax Collector, Bank Fees, Lic & Permits, Advertising,</i>
Office Supplies	\$ 1,831	\$ 6,600		\$ 6,600	\$ 4,769	28% <i>Office Supplies</i>
Operating Supplies	\$ 45,382	\$ 293,750		\$ 308,750	\$ 263,368	15% <i>Operating Supplies, Fuel, Gas & Oil, Aquatics</i>
Books & Training	\$ 2,300	\$ 7,000		\$ 7,000	\$ 4,700	33% <i>Books, Pubs., Memberships, Training Costs</i>
Restricted Reserves	\$ -	\$ 1,831,129		\$ 1,831,129	\$ 1,831,129	
OPERATIONS	\$ 283,818	\$ 2,615,382		\$ 2,615,382	\$ 2,331,564	11%
Capital Outlay						
Improvements Other than Buildings	\$ 16,708	\$ 25,000	\$ 10,928 1	\$ 35,928	\$ 19,220	47%
Machinery	\$ 4,663	\$ 324,164		\$ 324,164	\$ 319,501	1%
Computer Equipment	\$ -	\$ 2,000		\$ 2,000	\$ 2,000	0%
Computer Software	\$ 240	\$ 2,500		\$ 2,500	\$ 2,260	10%
CAPITAL OUTLAY	\$ 21,611	\$ 353,664		\$ 353,664	\$ 332,053	6%
TOTAL EXPENSE	\$ 849,633	\$ 4,705,804		\$ 4,705,804	\$ 3,856,171	18%

1 Approved 10-24-23

\$10928.00 from #5450000 Insurance to #5630001 Improvements other than Buildings to purchase 2 floats